

EXPLOSION PROOF TEMPERATURE SWITCH MODEL : T953 (953 Series)

WISE[®]

SERVICE INTENDED

T950 Series, Temperature Switch, are installed with micro contact suitable for corrosive fluid. Temperature measurement deadband is fixed.

CONSTRUCTION

EXPLOSION PROOF(Ex d IIC T6) CONTACTS

REPEATABILITY

±1.0% of Adjustable Range

ACCURACY

±2.0% of Full Scale

DIMENSIONS

Refer to Drawings Dimensions

TEMPERATURE ELEMENT

Liquid Filled

Organic Gas : -50°C to 150°C

WORKING RANGE

Maximum Scale Value



TD09 - 05

Standard Features

LOCATION OF STEM

Bottom Connection, Surface,
Case Mounting

CASE & COVER

Silver gray Finished Aluminium(ALDC)

CAPILLARY

Capillary : 1.6/0.2mm, 316SS

Armored tube : 6.6/4.5mm, 304SS

STEM OUT DIA.

8.0, 10.0 & 12.0mm
316SS

STEM CONNECTION

3/8", 1/2", 3/4" PT or NPT

CONTACTS

Micro Contact Type

One SPDT (Model : T953-1B3)

Two SPDT (Model : T953-2B3)

ORDERING INFORMATION

BASE MODEL

T953 : EXPLOSION PROOF TEMPERATURE SWITCH (Only available with single set point)

SWITCH FORM

- 1 : One SPDT
- 2 : Two SPDT

UNSHED CHARACTER

B3

STEM MATERIAL

1 : 316SS

CONNECTION

- D : 3/8"
- E : 1/2"
- F : 3/4

CONNECTION TYPE (CF : Compression Fitting)

- C : PT
- D : NPT
- E : CF + PT
- F : CF + NPT

STEM OUT DIA.

- 2 : 8.0mm
- 3 : 10.0mm
- 4 : 12.0mm (Standard)

RANGE(Refer to Scale Range Table)

XXX

**CAPILLARY LENGTH
(If direct mounting,
Specify Stem Length Code)**

- P : 2 metre
- Q : 3 metre
- S : 5 metre
- V : 8 metre
- X : 10 metre
- Z : Other

ACCESSORIES

- 0 : None
- 1 : Thermowell



**SAMPLE
MODEL
NUMBER**

TD09 - 05

T953 : TYPE OF MOUNTING

* Remote reading type

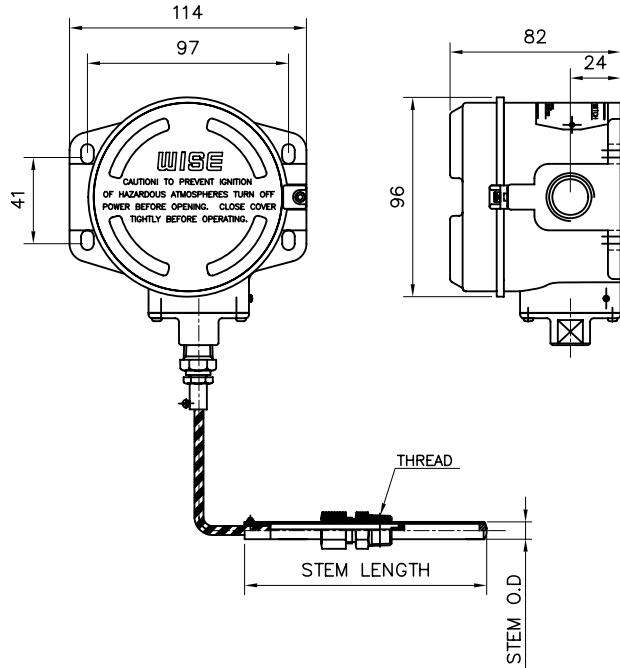

* Direct mounting type

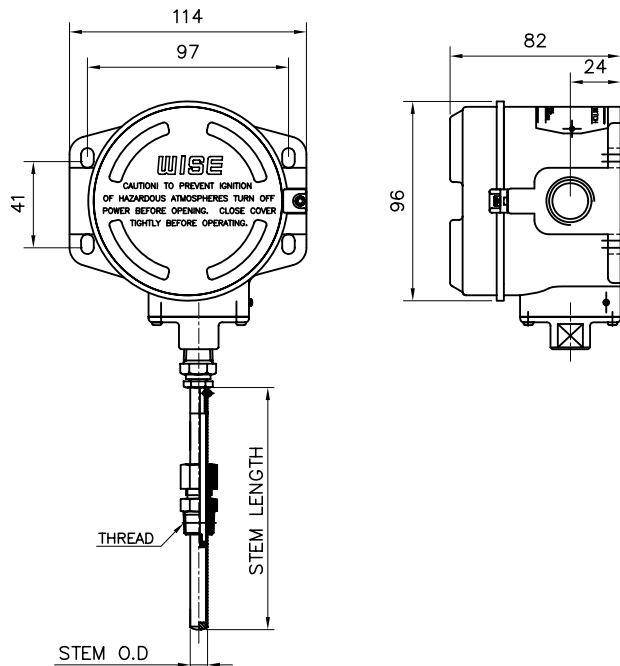

TEMPERATURE SWITCH

A bi-stable electro mechanical device than actuates/deactuates one or more electrical switching element at a predetermined discrete temperature upon rising or falling.

ADJUSTABLE RANGE

The span of temperature between upper and lower limited within which the temperature switch can be adjusted to actuate/deactuate. It is expressed for increasing temperature.

SET POINT

That discrete temperature at which the temperature switch is adjusted to actuate/deactuate on rising or falling temperature. It must fall with the Adjustable Range and be called out as increasing.

DEADBAND

The difference in temperature between the increasing Set Point and decreasing Set Point.

PROOF PRESSURE

The maximum input temperature that can be continuously applied to the pressure switch without causing permanent change of set point, leakage or or falling. material failure.

BURST TEMPERATURE

The maximum input temperature that can be continuously applied to the temperature switch without causing leakage or catastrophic material failure. Permanent change of Set Point may occur, or the device may be rendered inoperative.

REPEATABILITY

The ability of a temperature switch to successively operate at a Setpoint that is approached from a starting point in the same direction and returns to the starting point over three consecutive cycles to establish a temperature profile.

TEMPERATURE RANGES TABLE

Code	Adjustable Setting Range (°C)	Maximum Working Temperature (°C)	Minimum Stem Length (mm)			Standard Stem Length (mm)		
			8.0	10.0	12.0	8.0	10.0	12.0
032	-50~5	35	100	85	65	200	130	130
069	-5~65	75	100	88	65	200	130	130
104	20~90	95	100	85	65	200	150	130
106	50~120	130	100	85	65	200	130	130
114	100~170	180	100	85	65	200	130	130
119	150~220	230	100	85	65	200	130	130
120	190~260	270	100	85	65	200	130	130
124	230~300	310	100	85	65	200	130	130
038	-50~150	250	100	85	65	200	130	130

STEM LENGTH

Code	1	2	3	4	5	6	7	8	9	A	B
Length(mm)	50	60	70	80	90	100	120	130	150	200	225

Code	C	D	E	F	G	H	J	K	L	M	N
Length(mm)	250	275	300	350	375	400	450	500	1000	1500	2000

Code	P	Z
Length(mm)	2000	Longer than 2000

RATED VOLTAGE	RESISTANCE LOAD		INDUCTIVE LOAD	
	NC	NO	NC	NO
125V AC	15 (10)		15 (10)	
250V AC	15 (10)		15 (10)	
480V AC	10		10	
8V DC	15		15	
14V DC	15		10	
30V DC	2		1	
125V DC	0.4		0.03	
250V DC	0.2		0.02	

SPDT SWITCHING ELEMENT

Single-Pole, Double throw(SPDT) has three connection : C-Common, NO-Normally open and NC-Normally closed, which allows the switching element to be electrically to the circuit NO or NC state.

DPDT SWITCHING ELEMENT

Double-Pole, Double Throw(DPDT) is two SPDT switching elements operated by a common lever assembly so simultaneous actuation / deactuation occurs at both the increasing and the decreasing set point. Two independent electrical circuits can be switched, i.e. one AC and one DC.

T953 1B3 TYPE

When the input temperature reach the upper or lower limit set point, The circuit is closed and opened.

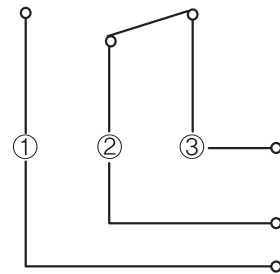
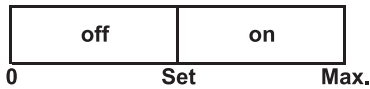

① : NO ② : COM ③ : NC

T953 2B3 TYPE

When the input temperature reach the upper or lower limit set point, Two circuit are simultaneously closed and opened.

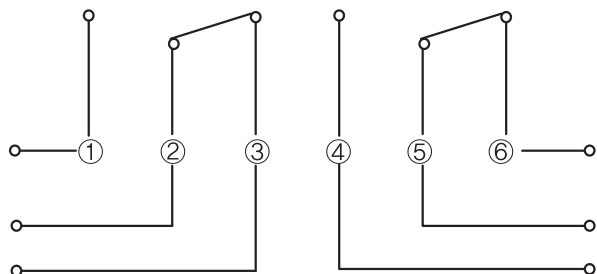
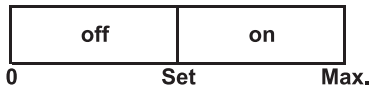

①,④ : NO ②,⑤ : COM ③,⑥ : NC

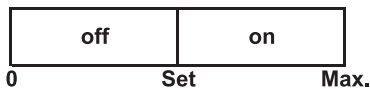

Standard Features

Code	Scale Range (°C)	Scale Spacing (°C)	Minimum Stem Length (mm)			Standard Stem Length (mm)		
			8.0	10.0	12.0	8.0	10.0	12.0
032	-50~50	2	100	85	65	200	130	130
037	-50~100	5	100	85	65	200	130	130
054	-30~50	2	100	85	65	200	150	130
059	-30~100	2	100	85	65	200	130	130
061	-30~120	5	100	85	65	200	130	130
069	-20~50	2	100	85	65	200	130	130
074	-20~100	2	100	85	65	200	130	130
079	-20~150	5	100	85	65	200	130	130
099	0~50	1	100	85	65	200	130	210
100	0~60	1	100	85	65	200	130	190
104	0~100	2	100	85	65	200	130	130
106	0~120	2	100	85	65	200	130	130
109	0~150	5	100	85	65	200	130	130
114	0~200	5	100	85	65	200	130	130
119	0~250	5	100	85	65	200	130	130
124	0~300	5	100	45	40	200	130	130
129	0~350	5	100	45	40	200	130	130
134	0~400	10	100	45	40	200	130	130
144	0~500	10	100	45	40	200	130	130
154	0~600	10	100	45	40	200	130	130
000	Special Range	Please Contact to Technical Dept.						

STEM LENGTH

Code	1	2	3	4	5	6	7	8	9	A	B	C
Length(mm)	50	60	70	80	100	120	130	150	175	200	225	250

Code	D	E	F	G	H	J	K	L	M	N	P	Z
Length(mm)	275	300	350	375	400	450	500	550	1000	1500	2000	Longer than 2000