

**UNION**  
**MODEL : A010**

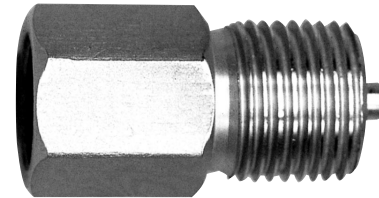

**SERVICE INTENDED**

It is used for adapting size of the pressure tap which is different with the size of the pressure instrument thread.



**ORDERING INFORMATION**

BASE MODEL - 1st thru 4th characters  
A010 : UNION

5th Character		6th Character		7th Character		8th Character	
Code	Unused Character	Code	Material	Code	Gauge Connection Size	Code	Gauge Connection Type
A		A	Brass	0	1/4"	A	PF(F)
		C	304SS	1	3/8"	B	PT(F)
		D	316SS	2	1/2"	C	NPT(F)
		F	316LSS	3	1/8"	D	UNF
		G	304LSS	4	7/16"	E	NPT(M)
		V	PVC	5	3/4"		
		Z	Other	9	Other	Z	Other

9th Character		10th Character		11th thru 15th Character	
Code	Process Connection Size	Code	Process Connection Size	Code	Unused Character
A	1/8"	G	PF(M)	A0000	With Vent Cock Plug
B	1/4"	H	PT(M)	B0000	
C	3/8"	J	NPT(M)		
D	1/2"	K	UNF		
E	3/4"	N	S.W		
F	1"	C	NPT(F)		
G	7/16"				
Z	Other	Z	Other		

**A010AC1BDHA0000 SAMPLE ORDERING NUMBER**

# A010 : UNION

AD01 - 01

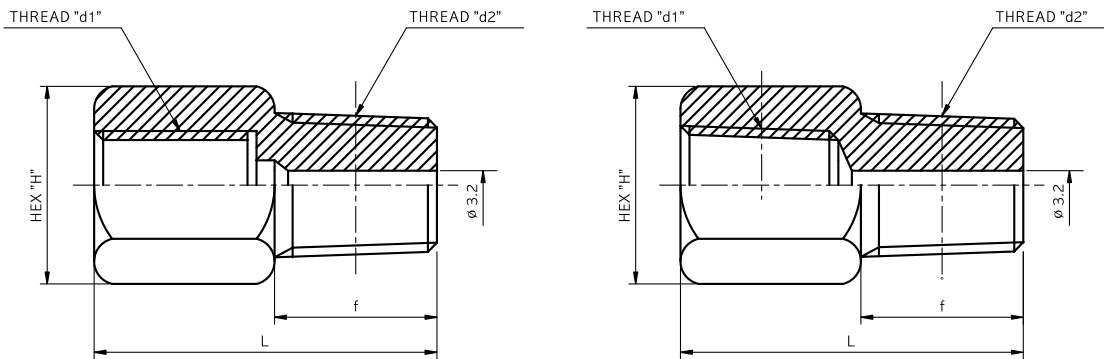
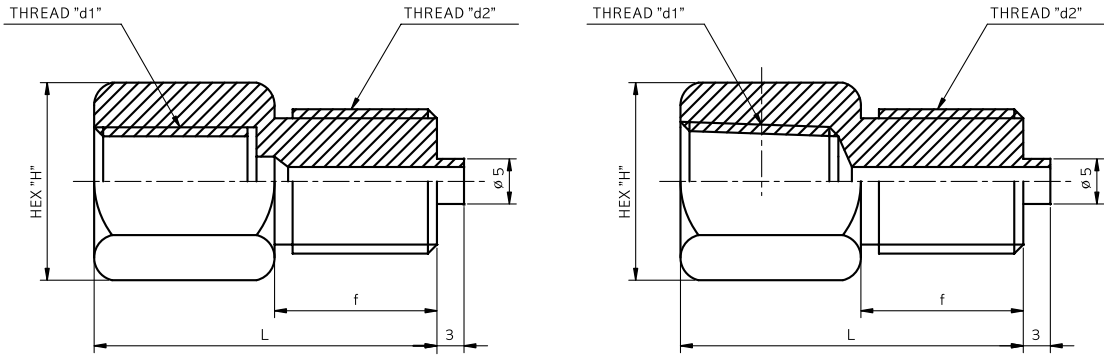

\* L : MAKER STANDARD

d1				d2			
	PF		1/4		PF		1/4
	PT		3/8		PT		3/8
	NPT		1/2		NPT		1/2
			3/4				3/4
SELECTION :							